



FXCM-7H-43B + FCX-53-02-0R
High-Temperature Zoom System for LEDEngin LZ7 LED

- **High efficiency**
- **Zoom system, spot-to-flood**
- **Color-mixing system**
- **Withstands extremely high temperature environments**

The FXCM-7H-43B color-mixing rod and holder assembly with FCX-53-02-0R imaging lens is specifically designed to efficiently collect the energy from the LEDEngin LZ7 LED and provide a color-mixed adjustable-angle beam. The mixing rod employs patent-pending technology to withstand extremely high temperatures, enabling luminaire manufacturers to design for higher current LEDs, and operate lamps in extremely high temperature environments.

Typical applications are:

- Entertainment Lighting
- General Illumination
- Architectural Lighting

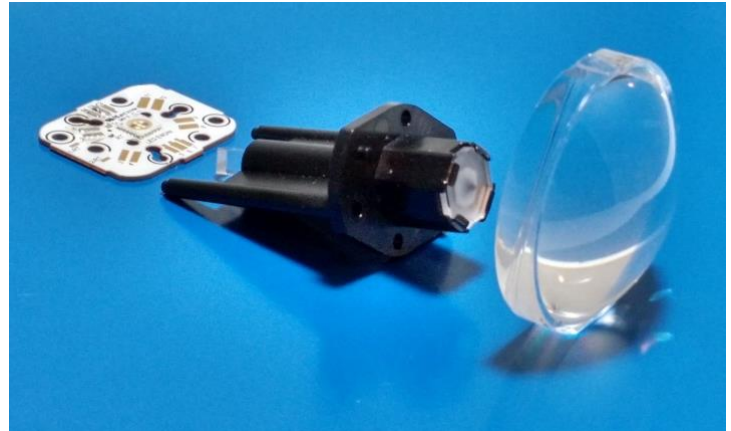

LZ7 is a trademark of LEDEngin. For technical specification on this LED please refer to the datasheet or visit:

<http://www.ledengin.com/products/emitters>

For ordering information, please contact:

FRAEN Corporation OMG	FRAEN Corporation Srl
80 Newcrossing Road	Via delle Querce, 22
Reading MA 01867	27020 Trivolzio (PV)
USA	Italy
Phone: +1 781.205.5300	Phone: +39 0382 1933.1
Fax: +1 781.942.2426	Fax: +39 0382 1933.239

Inquiries: optics@fraen.com

Website: FraenOMG.com



General Characteristics

Operating temperature:

The FXCM-7H-43B color-mixing rod and holder assembly and FCX-53-02-0R imaging lens materials are specially engineered to withstand extremely high operating temperatures. The maximum allowable temperature of the mixing rod at the LED interface is 250 °C.

Cosmetic defects:

Please note that small defects, flow lines, and weld lines on the surfaces of the lens are acceptable.

Optic handling and cleaning:

- Handling: Always handle the optics by the flange or holder. Do not touch the other surfaces of the optics with fingers; finger oils and contamination will absorb or refract light.
- Cleaning: Clean lenses only if necessary. Use only soap and water to clean the surfaces. CAUTION - Never expose the lens to alcohol or solvents as they could damage the plastic.

Scope

This datasheet provides information about the High-Temperature Color-Mixing Zoom System with LEDEngin LZ7 LEDs.

Optical Characteristics – On-axis Intensity¹, Beam Angle², Field Angle³

The measurements below were made using a single LEDEngin LZ7 seven-chip LED.

Beam Shape	On-axis Intensity (peak)	Beam Angle (FWHM)	Field Angle (FW10%)
Wide	0.7 cd/lm	56°	89°
Narrow	14 cd/lm	7°	9°

1. To calculate the on-axis intensity in candelas (cd), multiply the on-axis candela per lumen value, above, of the lens (cd/lm) by the total luminous flux in lumens (lm) of the LED used. Luminous intensity depends on the flux binning and tolerance of the LEDs. Please refer to the LED datasheet for more details on flux binning.
2. Beam angle is the full angle where the beam intensity is half the on-axis peak intensity
3. Field angle is the full angle where the beam intensity is 10% of the on-axis peak intensity.

NOTE: The beam shape in the “Narrow” position is octagonal. For multi-LED lamps, incrementally-rotating the LEDs will provide a rounder beam with further color-mixing.



Mechanical Characteristics

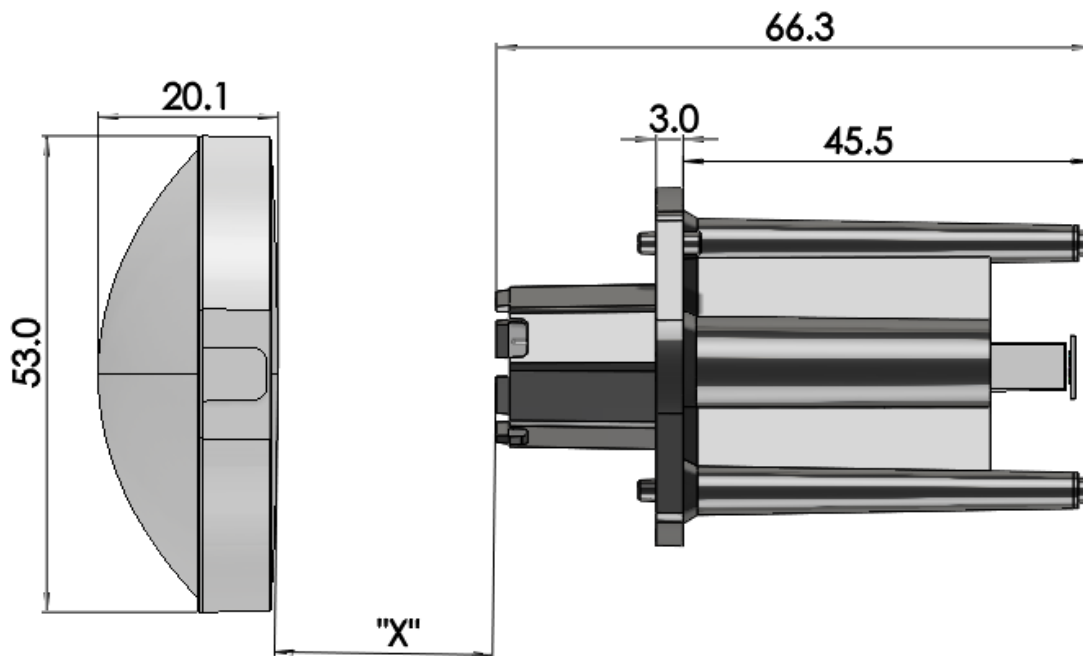
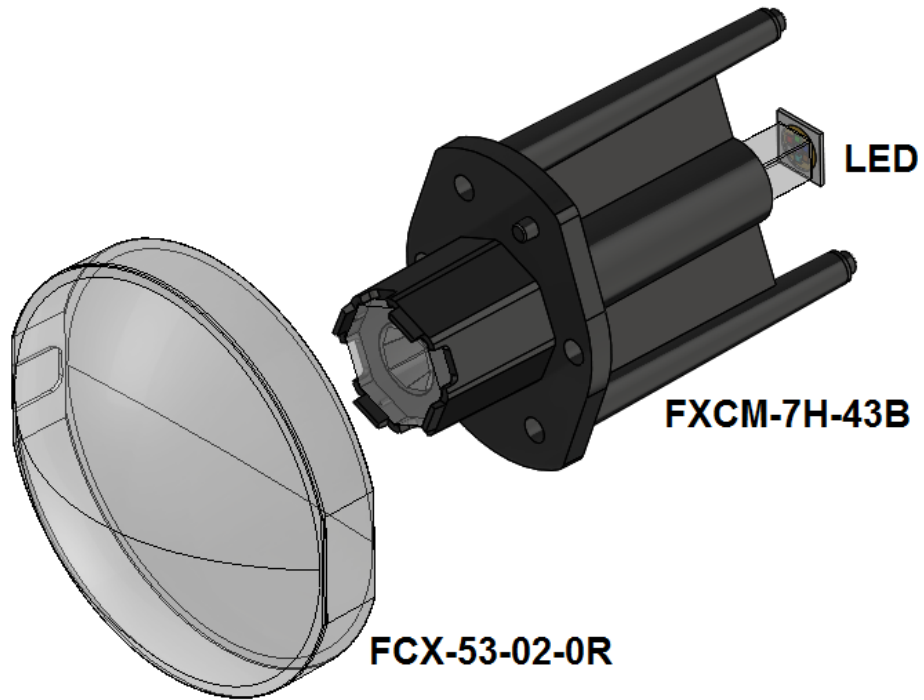

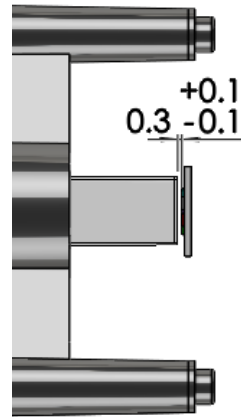
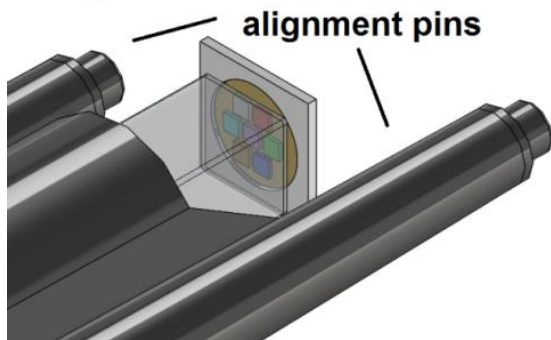

Dimensions are in millimeters.

NOTE: For best performance, the distance (gap) between the input surface of the clear mixing rod and the output surface of the LED should be 0.3 +/- 0.1 millimeters.

Wide Position: X = 1 mm
 Narrow Position: X = 45 mm

Ordering Part Numbers

FXCM-7H-43B (Rod + Holder Assembly)

Fraen Focusable Color Mixing
 Light Emitting Surface size (mm)
 Includes Holder
 43 mm mixing rod to mounting flange
 Black holder

FCX-53-02-0R (53 mm Lens)

Fraen Convex Focusable
 Lens diameter (mm)
 2nd Design
 No Holder, Round lens

The last two characters are 'zero R'

*Published by Fraen Corporation.
 All data contained in this document is the property of Fraen Corporation and may change without notice.*